



KORSCH
PRODUCT RANGE

XL 800

High Capacity



Double-sided and
Fully Automated
Tablet Press

KORSCH
The Specialist.

Innovations Made in Berlin Since 1919

Focus Drives Perfection

Specialization is the key. Since 1919, KORSCH has focused on its core competency of tablet compression technology.

This focus and resulting experience base is the foundation for the broadest and most innovative product line for tablet compression technology.

KORSCH offers an optimal solution for virtually every tablet compression application – through initial feasibility, research, scale-up, clinical production, and full scale 24/7 production.

KORSCH presses are used successfully all over the world and are supported by a global network of sales and technical service specialists.

www.korsch.com

The logo consists of three vertical bars of equal height, colored black, red, and gold from left to right, followed by the text "MADE IN GERMANY" in a bold, sans-serif font. The text is arranged in two lines: "MADE IN" on the top line and "GERMANY" on the bottom line.

MADE IN
GERMANY

High Capacity

The KORSCH XL 800 double-sided tablet press is the largest offering in the proven XL-series and was developed for high speed, high volume, and fully automated production. The XL 800 is the most productive tablet press in the world,

offering an extremely robust and rugged design which permits precision tablet weight control at the highest production speeds.

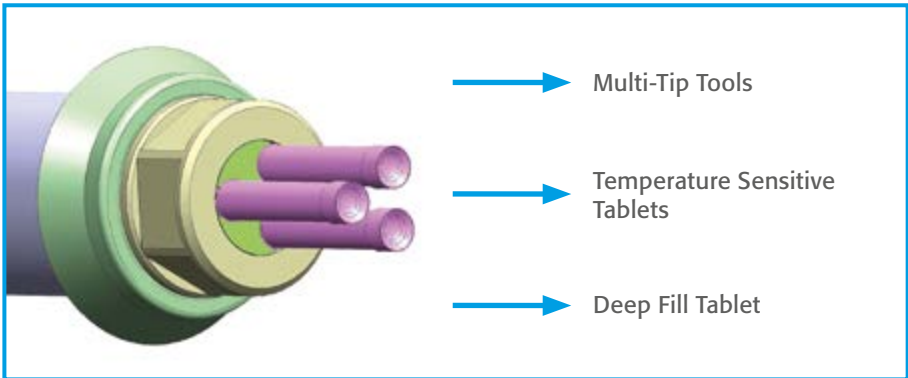
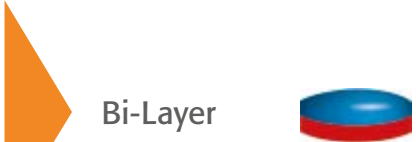
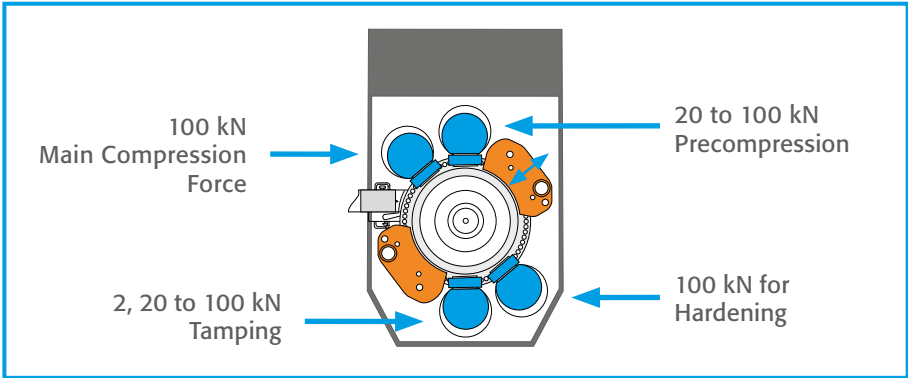
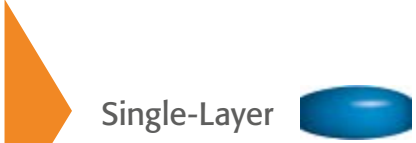
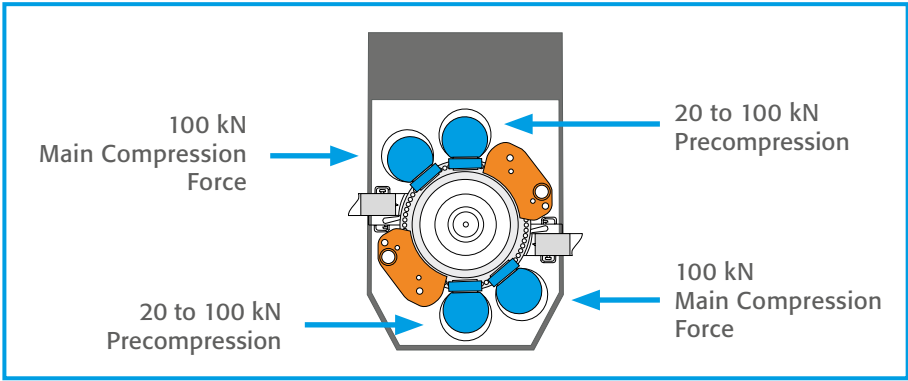

High Efficiency

The KORSCH expertise is the optimal utilization of the pitch circle of the tablet press, from die filling to tablet ejection. The design concept of the XL 800 including the rear multi-function cabinet with all major press components, and the open compression zone design, offers superior access for operation, cleaning, changeover, and maintenance. The

larger pitch circle of the XL 800 turret insures a long, smooth cam track design which permits maximum press speeds while maintaining precision weight control. The XL 800 uses standard EU and TSM press tools and a standard PLC based control system which is easily maintained and updated.

High Volume Production

The XL 800 is designed to run at high speed. The long feeder lengths, smooth cam tracks, 100 kN precompression and main compression stations, and the compression dwell bar all combine to permit maximum throughput without any compromise on product quality.

The use of multi-tip tools has been executed successfully on the XL 800, which permits an extreme improvement in tablet output, while maintaining tablet quality.

- Single-Layer Tablet Production to 1,000,000 tabs/hour
- Bi-Layer Tablet Production to 500,000 tabs/hour

High Precision at High Speeds

The XL 800 feeder design offers a larger filling length and a closed feeder design which insures precision weight control at the highest press speeds.

The unique compression dwell bar maintains pressure on the tablet between the precompression and main compression stations, and extends the compression dwell time. The result is improved tablet hardness and higher speed operation.

- Longer feeder dwell time for precision weight control at high speeds
- Independent speed control of each feeder paddle
- Extended compression dwell time with innovative dwell bar design

Multi-Layer Capability and Special Applications

The XL 800 offers an innovative Bi-Layer conversion kit which permits a single press to run both Single-Layer and Bi-Layer Tablet formats. The XL 800 also enables the production of tablets with special parameters, such as a large diameter or a deep fill, for example. The placement of the main drive system in the rear multi-function column insures no heat generation in the compression zone, and thus the perfect solution for temperature sensitive materials.



The benefits at a glance:



- High Efficiency
- User Friendly Operation
- Optimal Control and Full Compliance

User Friendly Operation

The design concept of the XL 800, with the multi-function column at the rear of the machine, and the carrier plate design which eliminates the need for corner columns around the compression zone – offers optimal access for machine

set-up, cleaning, changeover, and maintenance. The through-the-wall installation option offers the highest standard in GMP with access to all major machine components from the service area, outside of the compression suite.

Single and Bi-Layer Flexibility

The XL 800 offers a simple conversion kit to permit the press to produce both single and Bi-Layer Tablets. The machine may be converted during the course of a normal changeover for maximum flexibility. The Bi-Layer design features:

- Closed feeder design with integrated dust extraction to prevent cross contamination
- First layer sampling at production speeds using retractable second layer feeder
- Option to harden first layer sample to permit in process measurement
- Independent and automatic control of the first and second layer weight
- Single tablet rejection based on tamping or final compression force

Exchangeable Turret

The XL 800 offers an exchangeable turret design that permits the removal of the entire turret, including the upper cam track, upper punches, and dies. The turret can be removed in less than 10 minutes. A transport/service trolley permits the turret to be cleaned and re-tooled off-line. The turret exchange features:

- Retracting compression columns to permit turret removal
- Internal lift device with hydraulic actuation
- Hand held control box for simplicity and safety

Superior Accessibility to Compression Zone

The innovative carrier plate design of the XL 800 eliminates the traditional corner columns and offers extreme access to the compression zone for cleaning and maintenance. The feeder can be quickly dismantled without tools, and the dust extraction is fully integrated in the lower turret shrouding, which is also removed with quick disconnects.

- Superior access to compression zone (no corner columns)
- Superior access to the machine base and major components in the multi-function column



Minimal Noise and Vibration

The unique and patented design of the carrier plate, with pneumatic dampers, fully isolates vibration from the head piece and machine base.

The result is an extreme reduction in operating noise level, even with high compression forces and high press speeds.

- Very low noise emission < 80 dB(A)
- No vibration transmission to the floor of the compression room
- No segregation of powder in the feeding system which can occur with machine vibration



Optimal Control and Full Compliance

KORSCH controls are based on a standard Siemens or Allen-Bradley PLC. The touch screen HMI also uses industry

standards, including WinCC and WonderWare, which are operating on an industrial PC platform.



User friendly touch screen control

The main screen presents all important press parameters in a graphical format. The language may be changed at the push of a button.

- Press force control
- Single-tablet rejection
- Product recipe
- Batch reporting

21 CFR Part 11 Compliant

KORSCH controls permit full compliance with 21 CFR Part 11.

- Password login with four access levels
- Electronic audit trails (event log, alarm log, reject log)
- Product recipe version control
- Secure batch report file format for data integrity

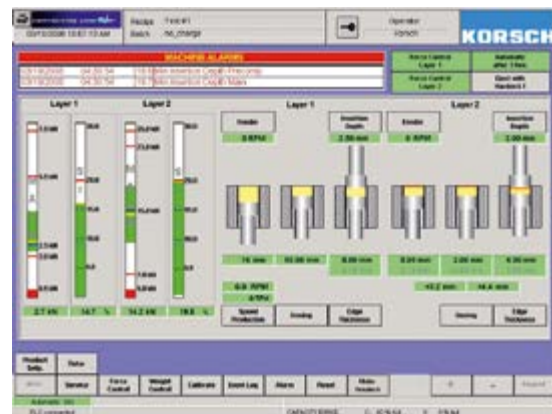



Special Features

The XL 800 offers a range of special features, including:

- DryCon Execution with OEB 3/4 containment capability
- WipCon® Execution with OEB 4/5 containment capability
- Deep fill (28 mm) for lollipop execution, tablet thickness to 14.5 mm
- Bi-Layer Conversion Kit
- Multi-Tip Tool Production

The technical data included in this document are optimal parameters and are dependent on product quality and machine settings.

KORSCH
The Specialist.

KORSCH Global Service Network

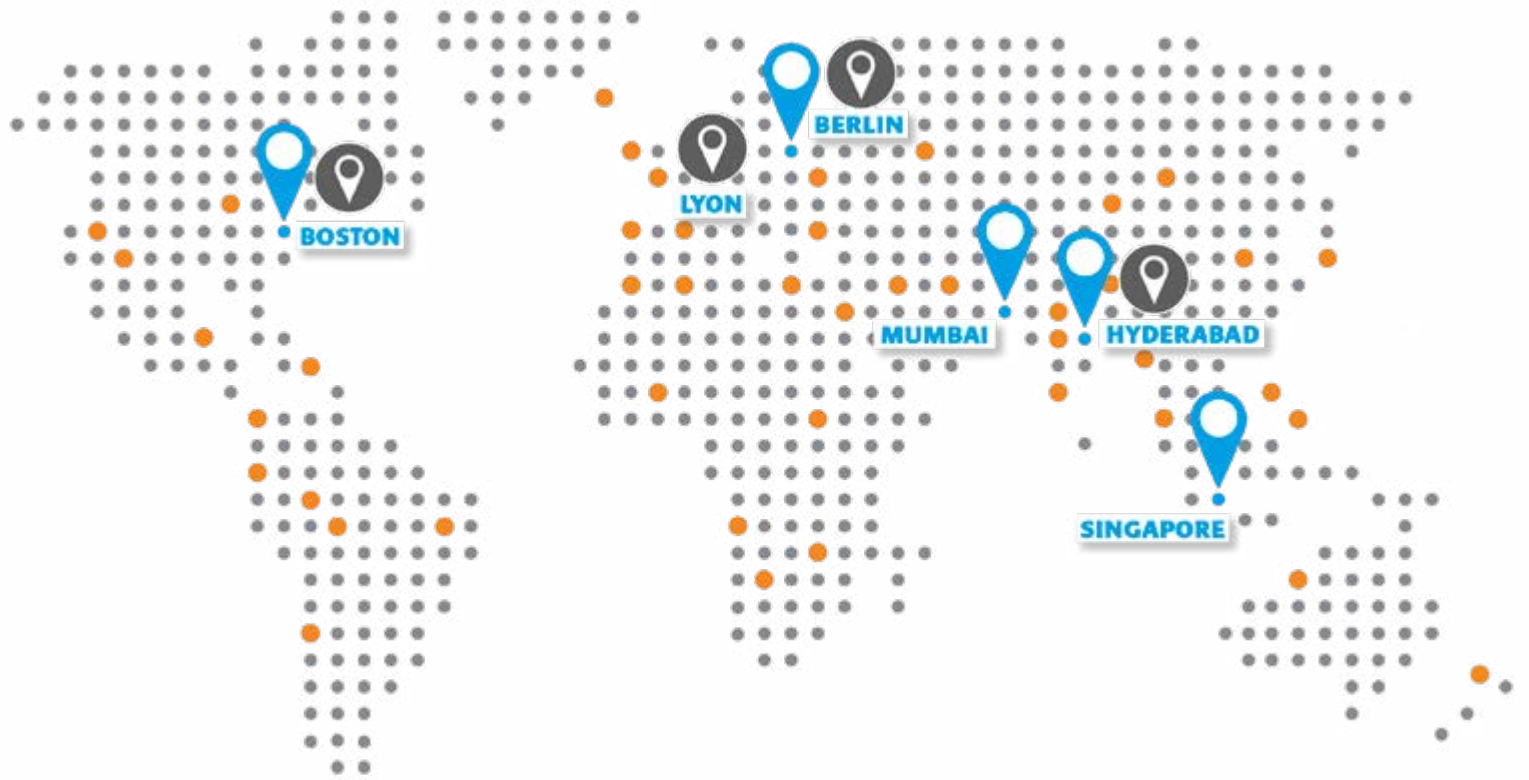



OUR SERVICE HELPLINE IN YOUR REGION:

 **Europe, Near East, Africa**
Phone: +49 30 43576-300
service@korsch.de

 **America**
Phone: +1-800-KORSCH-1
service@korschamerica.com

 **INNOVATION CENTERS**

 **Eastern Asia and South-East Asia**
Phone: +49 30 43576-300
service@korsch.de

 **Southern Asia**
Phone: +91 98 19004298
service@korschindia.com

www.korsch.com

